

Motors and Engines

Outline

- Review of Last Time
- Equivalent Circuit for Motor
- Homopolar Rotor

Electrical to Mechanical Energy Conversion

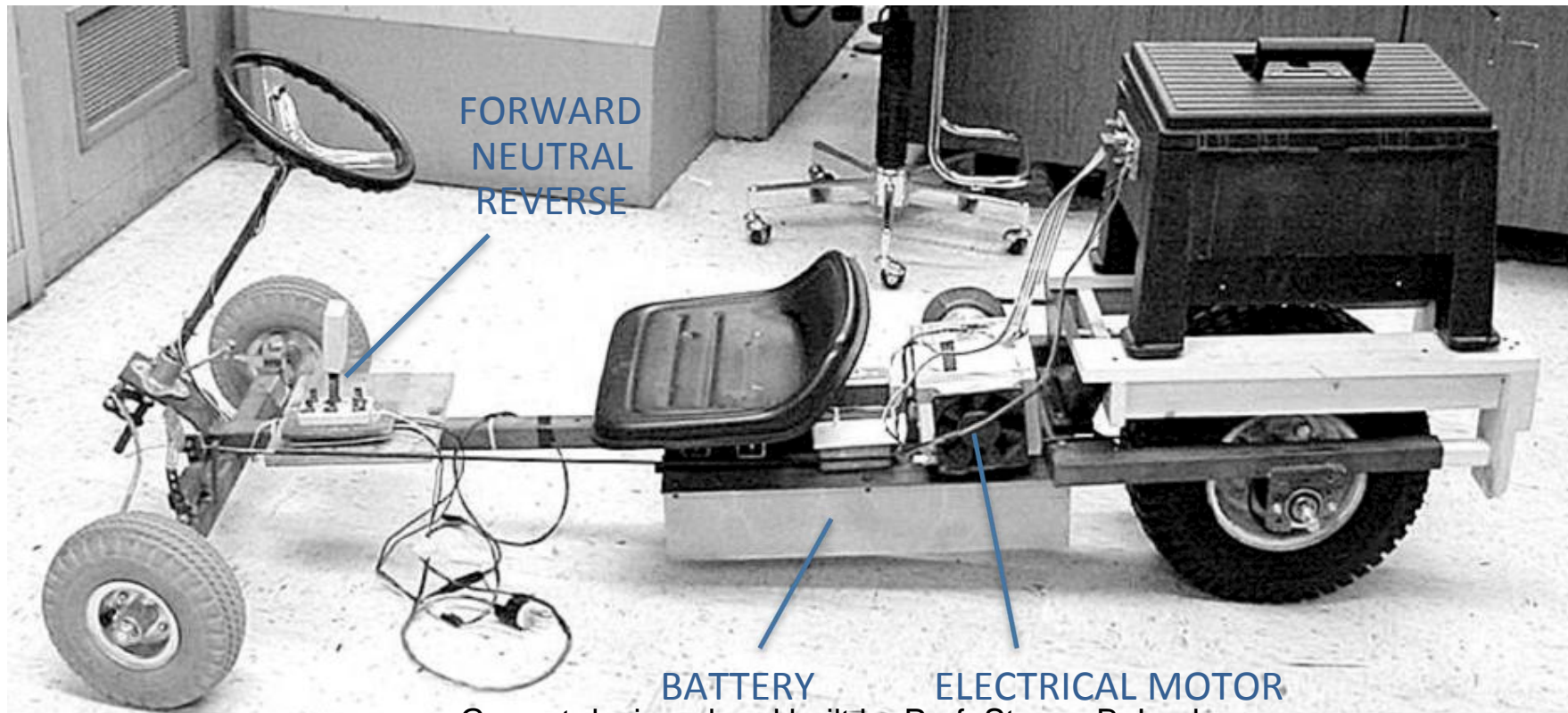

Go-cart designed and built by Prof. Steven B. Leeb,

To begin to understand the value of liquid fuels
(and the origins of the energy crisis facing the world)
we will make measurements and calculations on our go-cart.

Energy Flows in the Go-Cart

System of interest, e.g., Some type of Go-cart

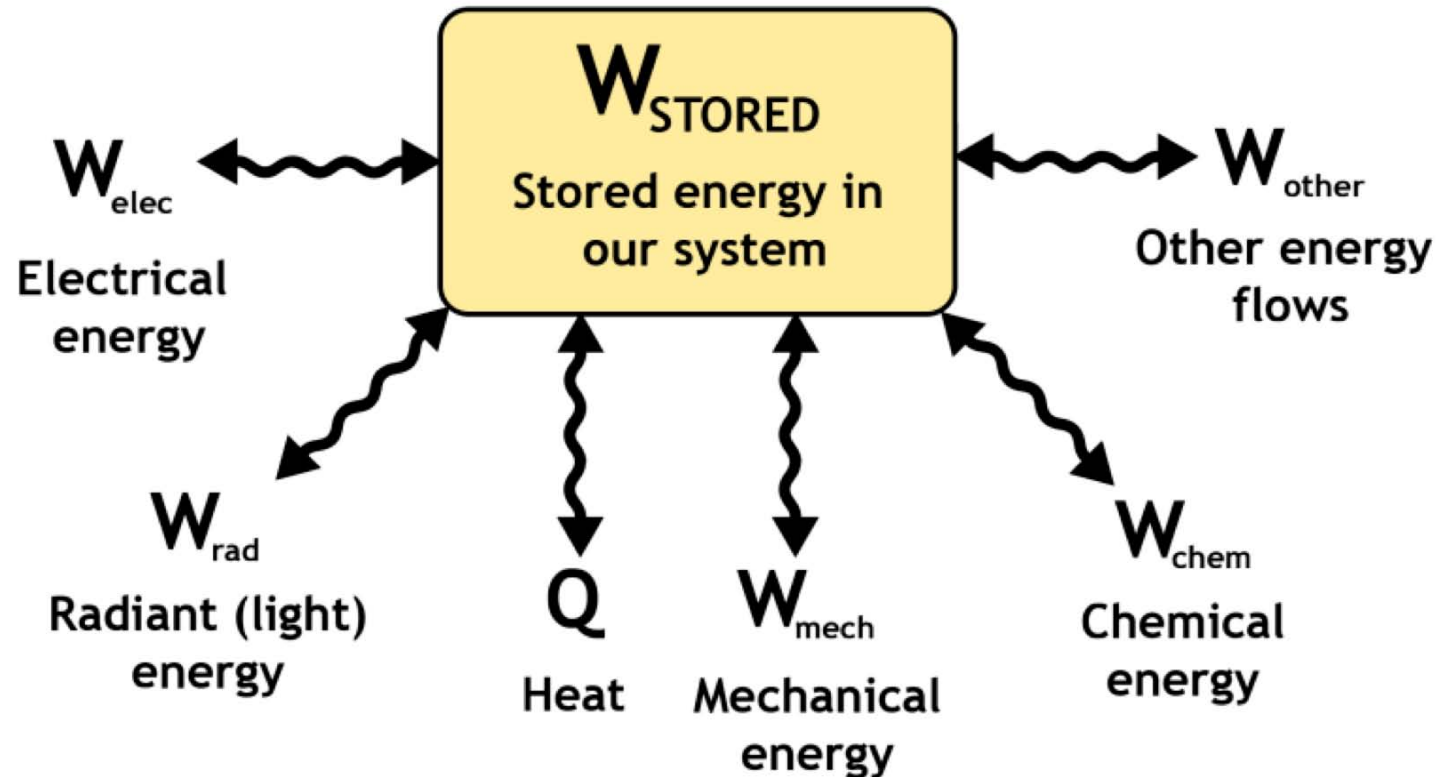

The first law of thermodynamics
"Energy is conserved"

$$W_{\text{stored}} = Q - \sum W$$

Review - Across and Through Variables

The ports of many energy conversion systems are conveniently described by a set of “through” and “across” measurements or variables. The different types of “through” and “across variables” distinguish different types of engineers (electrical, mechanical, chemical, etc.). The first and second laws apply to everyone.

“ACROSS” variables typically measure how hard we are “pushing”.

Typical “across” variables include:

Force, from mechanical engineering, measured in Newtons ($N = \text{kg} \cdot \text{m} / (\text{s} \cdot \text{s})$)

Voltage, from electrical engineering, measured in volts (V)

Torque, or twisting force, from mechanical engineering, measured in N-m

Pressure, from ocean/aero engineering, measured in $\text{N} / (\text{m} \cdot \text{m})$

Associated “THROUGH” variables typically measure how much “stuff” is flowing:

Velocity, from mechanical engineering, measured in meters/sec (m/s)

Current, from electrical engineering, measured in Coulombs/sec or Amps

Angular Velocity, from mechanical engineering, measured in rads/sec

Flow, from ocean/aero engineering, measured in volume/sec or $\text{m} \cdot \text{m} \cdot \text{m} / \text{s}$

POWER is the product of an “across” variable and a “through” variable.

Let's Drive the Electric Go-Cart on a Level Smooth Surface

Measure the voltage across the drive motor terminals and the current flowing into the motor when the go-cart reaches a “steady-state” or cruising speed.

In steady state, our measurements are:

Current flowing into the motor =

15 A

Voltage across the motor terminals =

36 V

Steady-state velocity of the cart =

12 miles/hour

Now, calculate the steady-state power consumed by the electric motor =

540 W

Range of the go-cart
at the steady state-velocity =

13.6 miles

Some statistics about the go-cart and its components:

Battery pack = 36 volts (nominal), 17 Amp-hours capacity
(can provide 17 amps for 1 hour, or 1 amp for 17 hours)

Battery pack weighs 36 pounds

Why does the Go-Cart use Energy

when Moving at a Steady-State Velocity ?

When the cart is moving, it has a certain amount of stored or “kinetic” energy. In steady-state, the velocity of the vehicle is constant, and the stored kinetic energy of the vehicle is also constant. Nevertheless, the electric motor in the go-cart consumes a certain amount of power or energy per second while the go-cart was driving at a steady speed.

Where does this energy go?

What physical mechanisms in the cart consume energy while the cart is moving?

Microscopic Heat & Friction

Rotational Dynamics (Quick Review)

Linear	Rotational
x	θ
F	τ
$F = m a$	$\tau = I \alpha$
Friction force = $b v$	Friction torque = $\beta \omega$
Work = $F d$	Work = $\tau \theta$
Power = $F v$	Power = $\tau \omega$

High-Level Model of Motor

The go-cart motor is NOT a resistor !!! It does not obey Ohm's Law.

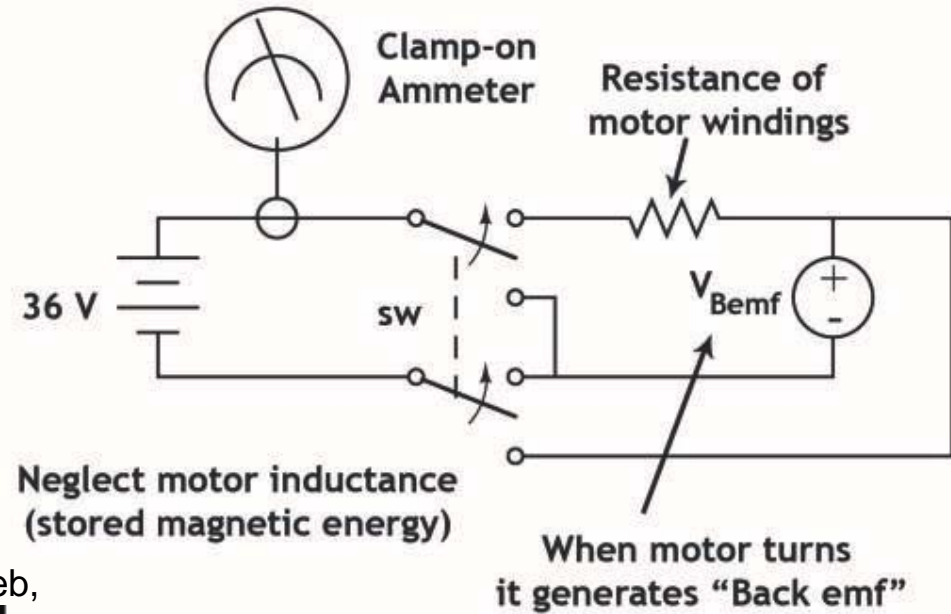

VOLT METER

Go-cart designed and built by Prof. Steven B. Leeb,

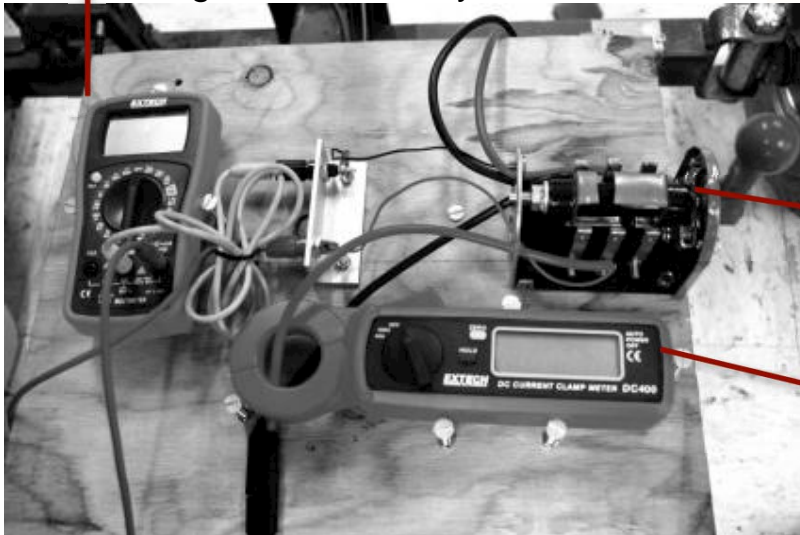

SWITCH
Forward-Off-Reverse

CLAMP-ON
AMMETER

Back Electromotive Force

MOTOR: When we put electrical energy into the lossless motor, it must “come out” as motion of the mechanical shaft.

GENERATOR: If we put mechanical energy into the shaft (by turning it) it must “come out” the electrical port.

The 1st Law requires that any contraption that can be used as an electromechanical actuator, i.e., some kind of motor, can also be used, somehow, as a generator.

The dependent source or “Back EMF” is a convenient circuit symbol to acknowledge our understanding of this first law requirement. If we put electrical power into the source, it “transduces” it to mechanical shaft power. If we turn the shaft, we must generate a voltage.

A Loudspeaker is Another Device Example of the 1st Law:

If we drive a speaker electrically, it makes sound (a typical loudspeaker or motor). If we talk into the speaker, it makes a voltage (a typical microphone or generator).

High-Level Model of Motor

The go-cart motor is NOT a resistor !!! It does not obey Ohm's Law.

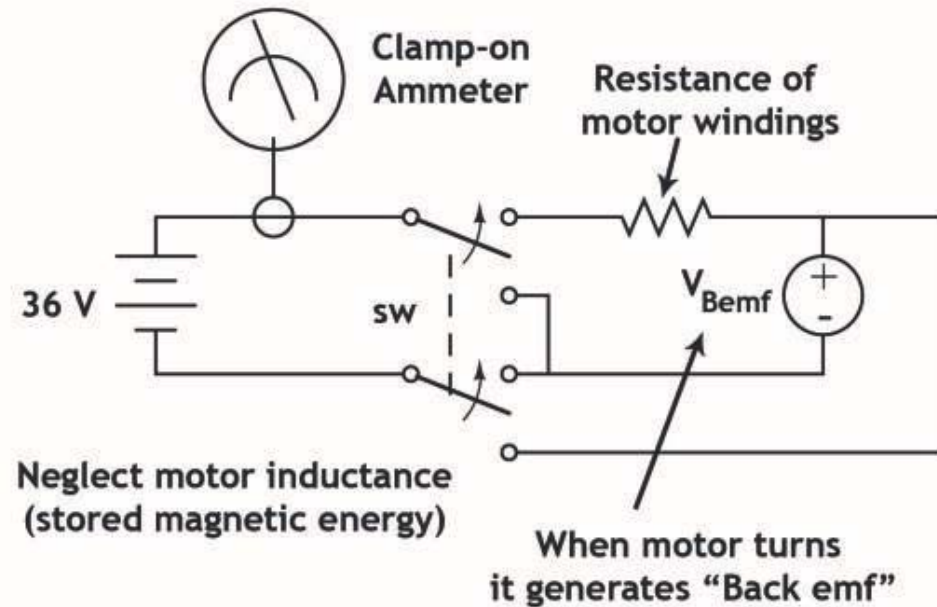

τ_m is the torque from the motor

Energy balance (from yesterday) tells us that ...

$$Power = \tau\omega = iV_{B_{emf}}$$

In steady-state, turning at a constant velocity ... the net torque is zero

$$\tau_m = \tau_f = \beta\omega$$

How do we relate the current/voltage to the torque ?

A Closer Look at Motors

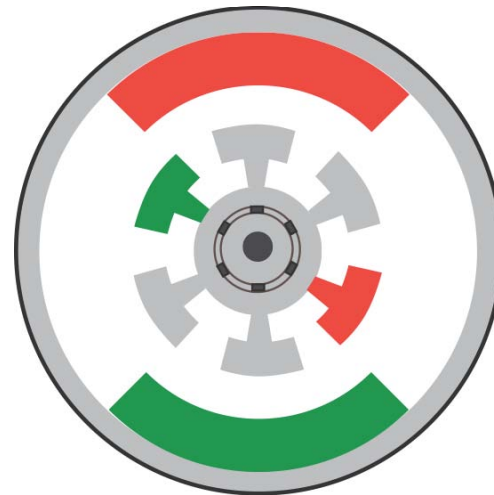
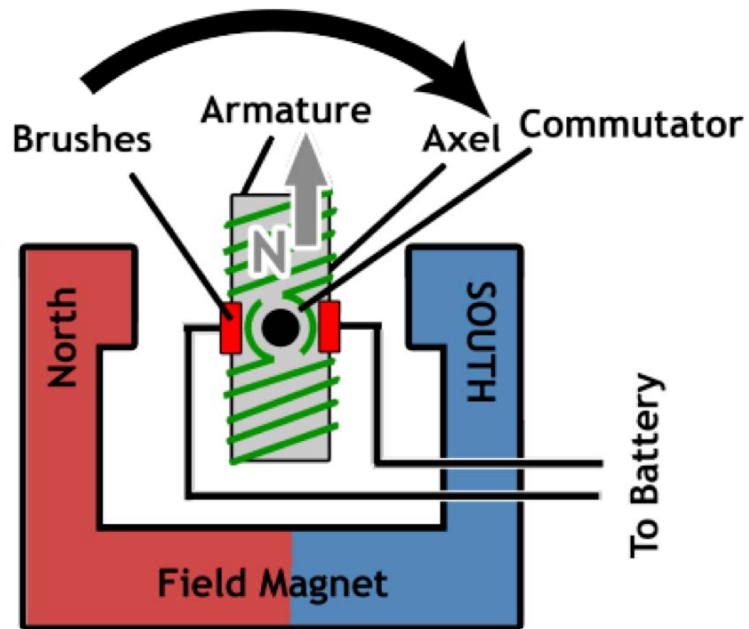
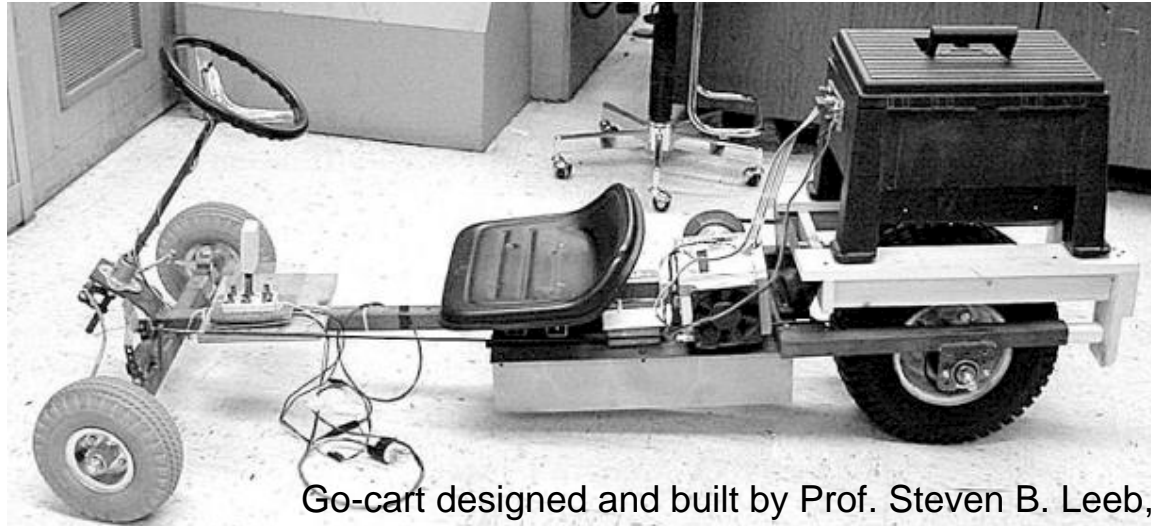

Homopolar Generator

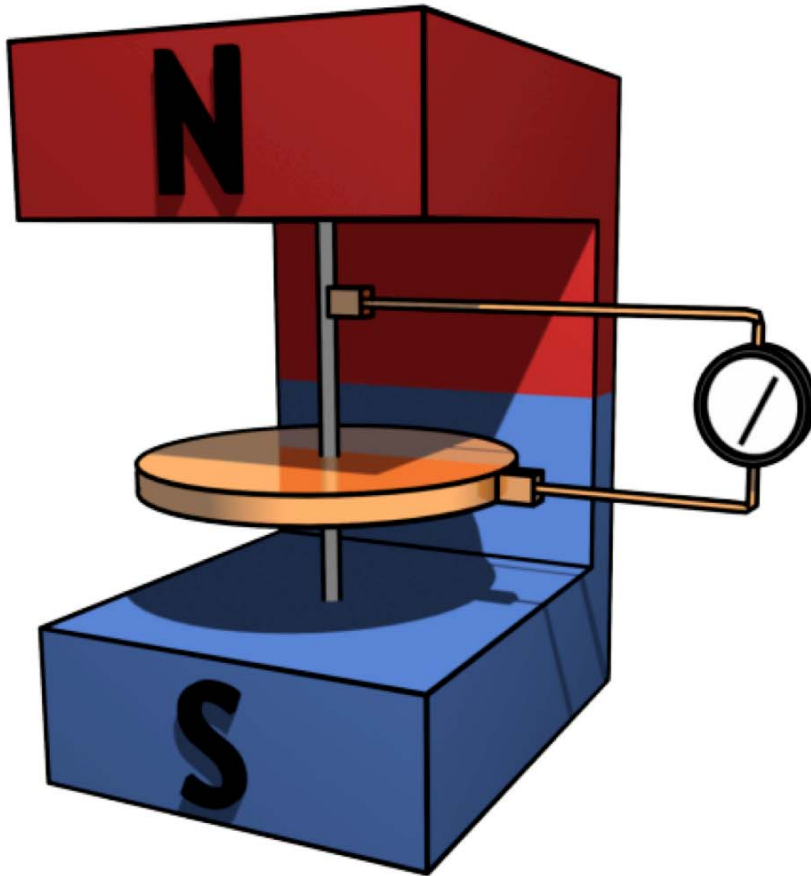

Torque is
proportional to Current

$$\tau_m = K I$$

↑
KNOWN AS THE
“MOTOR CONSTANT”

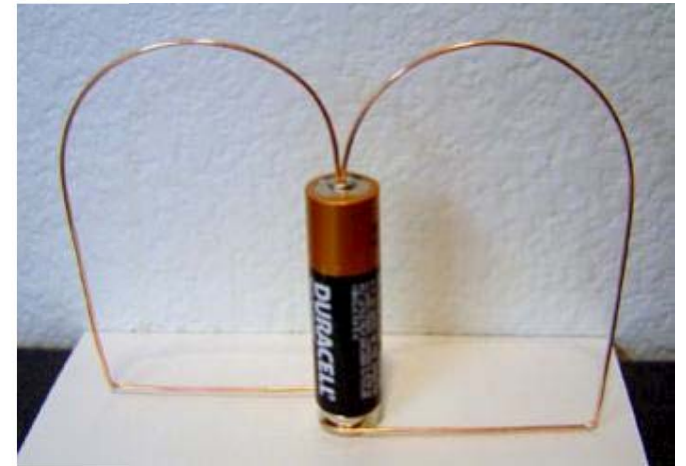

$$\bar{f} = q(\bar{E} + \bar{v} \times \mu_0 \bar{H})$$

Note that this law does not explain forces on dielectrics or magnetically permeable materials. Most common actuators employ these forces.

Motor Torque and Angular Velocity (when STEADY CURRENT is applied)

Torque is proportional to current

$$\tau_m = KI$$

IF WE APPLY STEADY CURRENT ON THE MOTOR ... then in steady state operation ...

Speed & Current vs. Torque — Speed — Current

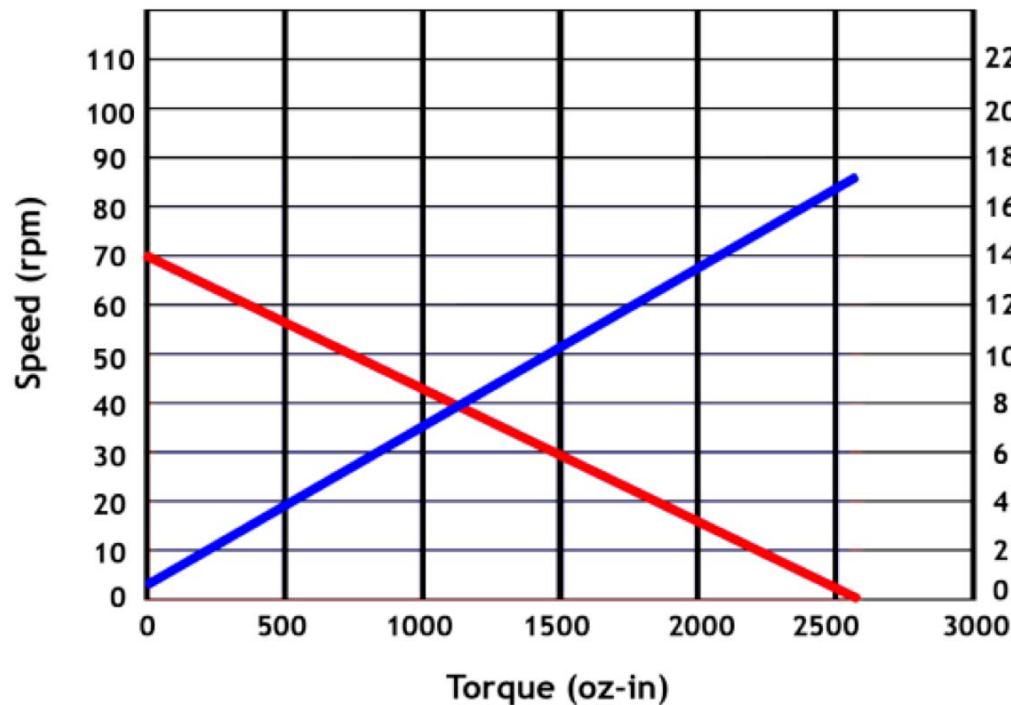

$$\tau_m = \tau_f$$

where τ_f is the frictional torque

$$\tau_f = \beta\omega$$

CONSTANT WHICH DEPENDS ON FRICTION COEFFICIENT and MOMENT ARM (EMPIRICALLY DETERMINED)

ANGULAR VELOCITY

$$\omega_{ss} = \frac{K}{\beta} I$$

STEADY STATE

Motor Torque and Angular Velocity (when STEADY VOLTAGE is applied)

The go-cart motor is NOT a resistor !!! It does not obey Ohm's Law.

HIGH-LEVEL MODEL of a MOTOR

$$Power = \tau\omega = iV_{B_{emf}}$$

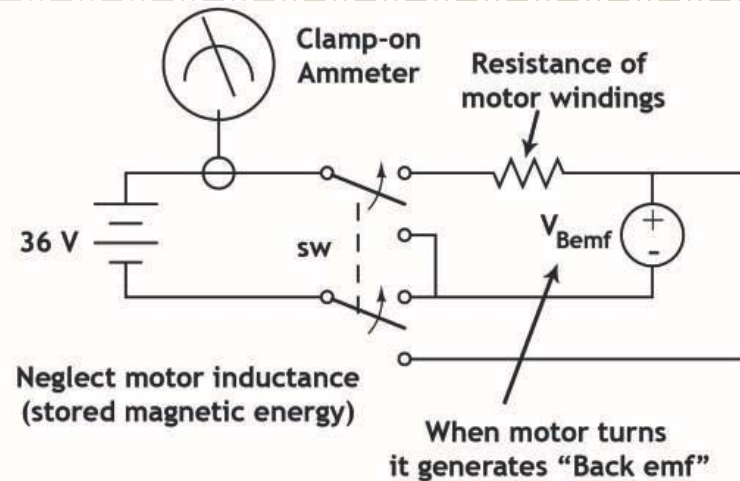

IF WE APPLY STEADY VOLTAGE, V_a , ON THE MOTOR ... then in steady state operation ...

Current through the motor in the steady state is $(V_a - V_{B_{emf}})/R$

$$\Rightarrow \tau_m = KI = K \frac{V_a - V_{B_{emf}}}{R} = \frac{K(V_a - K\omega_{ss})}{R} = \frac{K}{R} \left(1 - \frac{K^2}{K^2 + R\beta} \right) V_a$$

the back EMF is $K\omega$

equate τ_m to the frictional torque, $\tau_f = \beta\omega$

$$\frac{K(V_a - K\omega_{ss})}{R} = \beta\omega_{ss} \Rightarrow \omega_{ss} = \frac{K}{K^2 + R\beta} V_a$$

ω_{ss} happens to be linear in V_a

Steady State Speed as function of Motor Constant, K

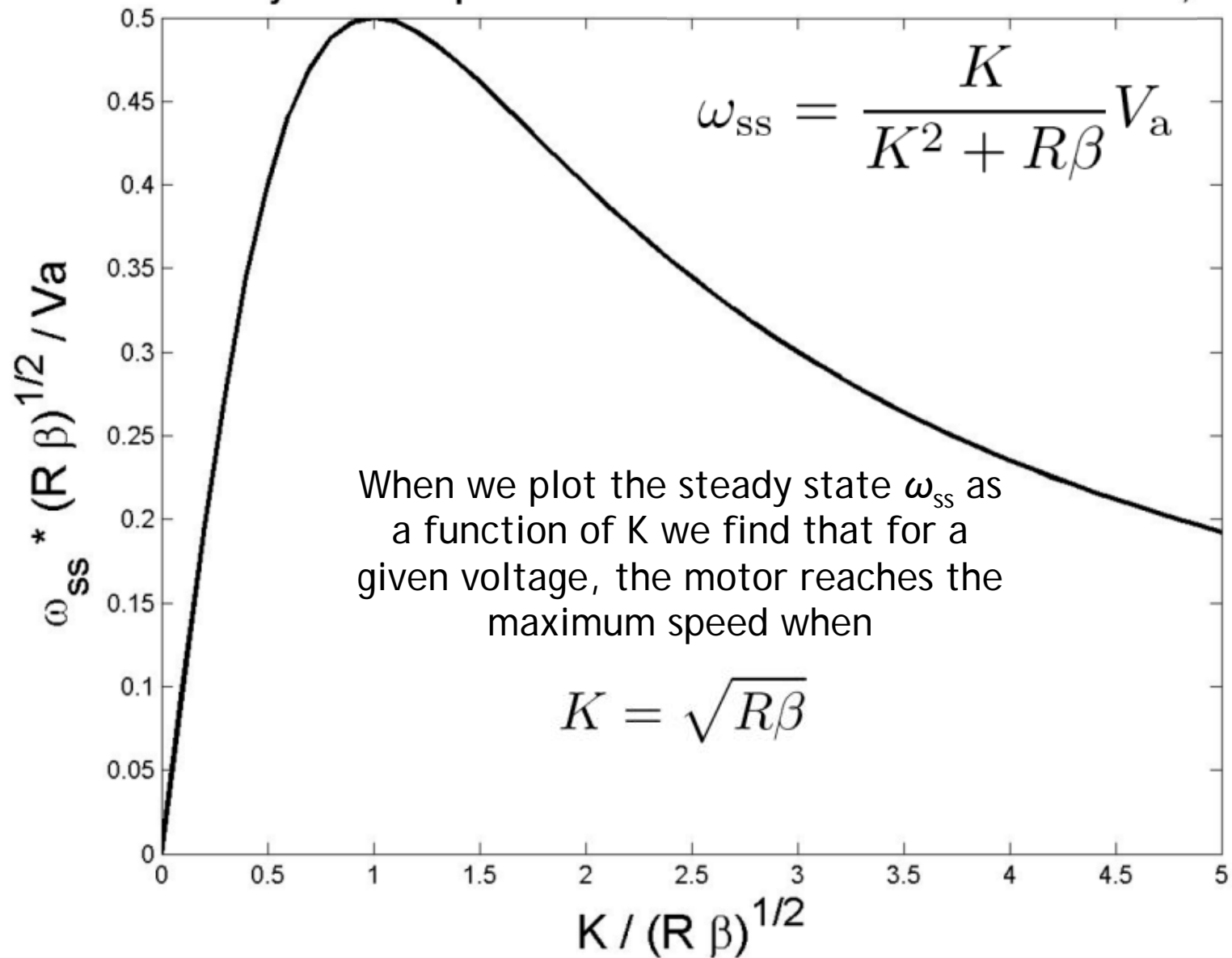

There are lots of different motors...

DC Brushless

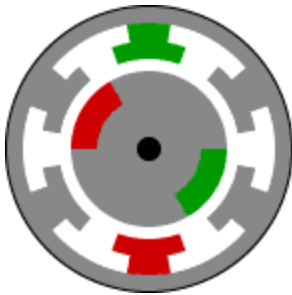

Stepper Motor

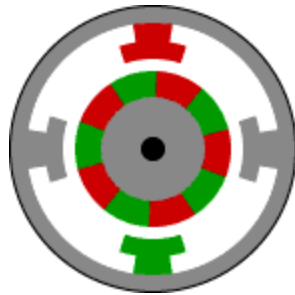

Reluctance Motor

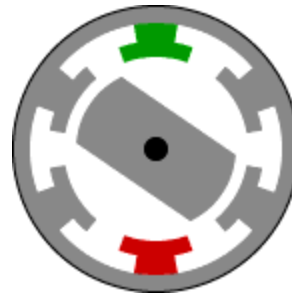

Induction Motor



http://www.freescale.com/files/microcontrollers/doc/train_ref_material/MOTORTUT.html

© Freescale Semiconductor, Inc. All rights reserved. This content is excluded from our Creative Commons license. For more information, see <http://ocw.mit.edu/fairuse>.

The E&M can be intimidating as you have to keep track of ...

- ... time-varying fields
- ... wild geometries
- ... magnetic materials and coils
- ... rotational dynamics

Electrical motors can
convert electrical energy into motion
with 90% efficiency

Let's Drive the Electric Go-Cart on a Level Smooth Surface

Measure the voltage across the drive motor terminals and the current flowing into the motor when the go-cart reaches a “steady-state” or cruising speed.

In steady state, our measurements are:

Current flowing into the motor =

15 A

Voltage across the motor terminals =

36 V

Steady-state velocity of the cart =

12 miles/hour

Now, calculate the steady-state power consumed by the electric motor =

540 W

Range of the go-cart
at the steady state-velocity =

13.6 miles

Some statistics about the go-cart and it's components:

Battery pack = 36 volts (nominal), 17 Amp-hours capacity
(can provide 17 amps for 1 hour, or 1 amp for 17 hours)

Battery pack weighs 36 pounds

Energy Losses of the Electrical Go-Cart

We have estimated the electrical losses (resistance) by carefully measuring the terminal resistance of the motor with a good ohm meter at several rotor positions and then averaged the results to compute approximately 1.2 ohms. There may be other electrical losses not accounted by this method, but this is a start.

Using our current, voltage, and speed measurements:

What is the electrical power loss for the go-cart in steady-state driving?

270 W

What, therefore, must be the power lost to mechanical friction in steady state?

270 W

Hypothetical Gas-Powered Go-Cart:

Let's make a comparison to a similar go-cart powered by a reasonably sized gasoline engine and gas tank. Let's replace the 36 pounds of batteries by a gas tank that holds 36 pounds of gasoline.

- Gasoline weighs 6 pounds per gallon,
- Gasoline stores 40,000 Watt-hours of heat energy per gallon. That is, if you burned a gallon of gasoline, you would get 40,000 Watt-hours worth of heat.

How many joules are stored in a gallon of gasoline?

144,000,000 J

How many gallons of gas are stored in the hypothetical go-cart gas tank?

6 gallons

How many joules of heat energy are stored in the go-cart gas tank?

864 MJ

- With 10% efficient engine we can deliver 86.4 MJ of mechanical energy
- We need 270 W to operate the car ... so we can operate it for ...
... 320,000 seconds = 88.8 hours ~ 1,000 miles (at the speed of 12 miles/hour)

Which go-cart is more energy efficient?

Which go-cart is more economical ?

ELECTRICAL

vs.

GAS-POWERED

17 A-hour battery at 36 V
(or 614 W-hours)

To charge the battery we need to burn coal (in a power plant) at 30% efficiency and run an efficient mechanical motor with up to 90% efficiency

→ **27% efficient** process
of converting coal energy into motion

Average national cost of electrical energy is ~\$0.10 per kW-hour
To charge the battery we then spent
 $0.614 \text{ kW-hr} * \$ 0.10 (\text{kW-hr})^{-1} = \0.06
→ **\$.005 per mile**

Gas powered car engines are
~**10% efficient**

For the 6 gallons of gasoline we spent
 $6 * \$3 = \18
and we traveled 1,000 miles
→ **\$.018 per mile**

*Next Time
we will consider
different methods of*

**Energy Storage in
Hybrid Vehicles**

*to solve the “mystery” of
why gasoline is so efficient
in storing energy*



Prius in Public Domain

In each case, energy is stored in charge separation ...

CAPACITOR



Image is in Public Domain

BATTERY

Prius NiMH:
0.035 kW-hr/kg

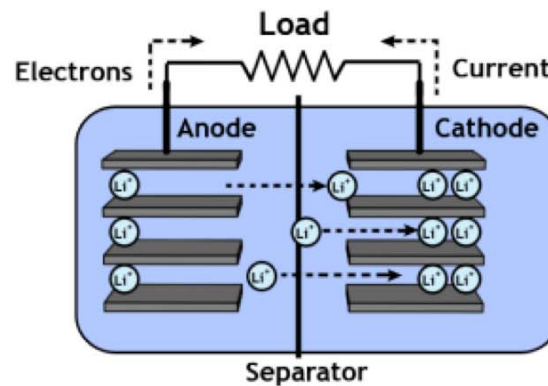

GASOLINE

1 gallon:
13 kW-hr/kg

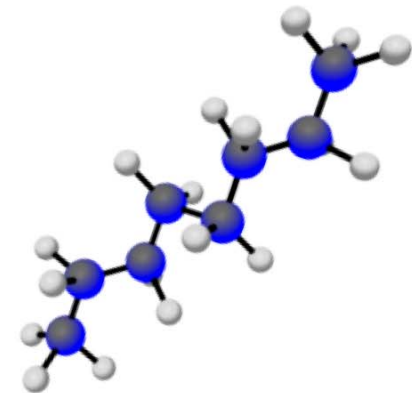

Energy stored in 1 gallons of gasoline is 35 kW-hr (or rounding-up 40 kW-hr)

This is equivalent to the energy stored in each of the following:

20 fast-food meals (burger, fries, drink, at 1,500 calories per meal). The human body converts the chemical energy from food into mechanical energy and body heat. When you buy food, you are buying energy to keep your body running.

1 piece of firewood (15 pounds piece, 20% moisture). Firewood is the major source of energy in many parts of the world.

10 pounds of coal. Coal is the most abundant fossil fuel on earth. It is a major source of fuel for power plants.

1.198 therms of natural gas. Natural gas is sold by the therm. A therm is equivalent to 100,000 British Thermal Units (BTU) of energy, and it takes about a hundred cubic feet of natural gas to make up a therm.

2145 pounds of lead-acid batteries. The energy stored in lead acid batteries starts cars and runs golf carts and electric cars.

1 gallon of gasoline weighs 6 lbs ~ 2.75 kg

The bulk of a typical gasoline consists of hydrocarbons
with between 5 and 12 carbon atoms per molecule.

KEY TAKEAWAYS

When motor turns it generates “Back EMF”

- The 1st Law requires that any contraption that can be used as an electromechanical actuator can use its actuation to generate EM fields:
 - a motor can also be used as a generator.
 - a loudspeaker can also be used as a microphone

- Torque of a motor = motor constant × motor current $\tau_m = KI$

- When frictional torque in a motor equals the torque from the Lorentz force inside the motor, the net torque is zero and a steady operation is achieved.

Frictional Torque = constant × angular velocity $\tau_f = \beta\omega$

- Operated at CONSTANT CURRENT - motors have steady angular velocity
- Operated at CONSTANT VOLTAGE - motors have steady torque
- Energy stored in 1 gallons of gasoline is 35 kW-hr (or rounding-up 40 kW-hr)
- Electric vehicles are more economical per mile traveled, however, they can travel fewer miles since the batteries store less energy per kg than fuel does

MIT OpenCourseWare
<http://ocw.mit.edu>

6.007 Electromagnetic Energy: From Motors to Lasers
Spring 2011

For information about citing these materials or our Terms of Use, visit: <http://ocw.mit.edu/terms>.